

BEFORE YOU BEGIN

1. Read these instructions and check to be sure all parts and tools are accounted for.
2. Please retain these installation instructions for future reference and parts ordering information

IMPORTANT

1. Please read the installation instructions carefully before you start.
2. If the vehicle is clean and free of other debris, it will be easy to install.
3. For your safety and to ensure a satisfactory installation, please complete all the installation steps in the order shown below.

PRODUCT INFORMATION:

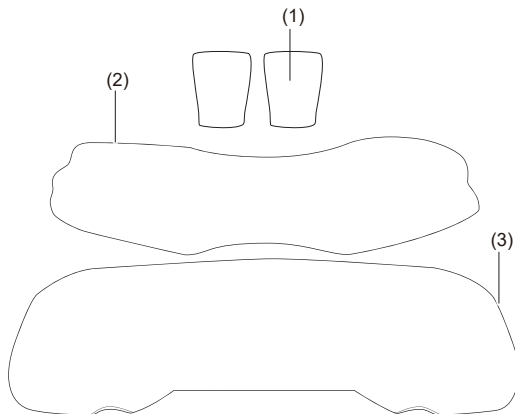

- 01 Headrest cover x2
- 02 Back seat cover x1
- 03 Bottom seat cover x1

INSTALLATION TIPS:

BENCH SEAT

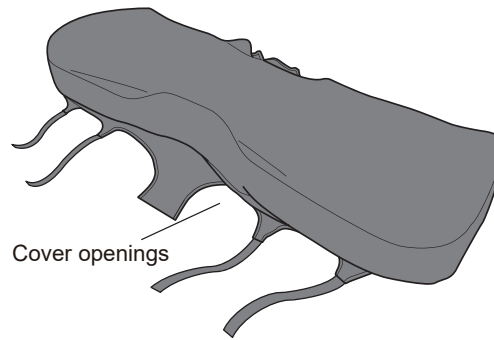
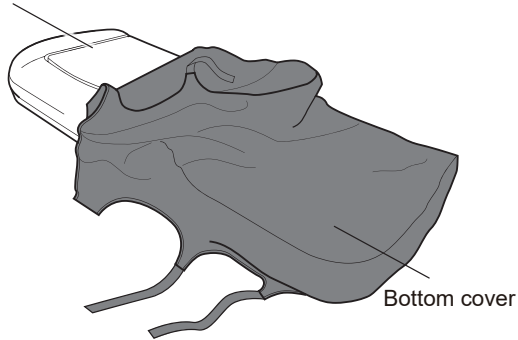

1. Place bottom cover on one side of bench seat, pull it to cover entire of seat.

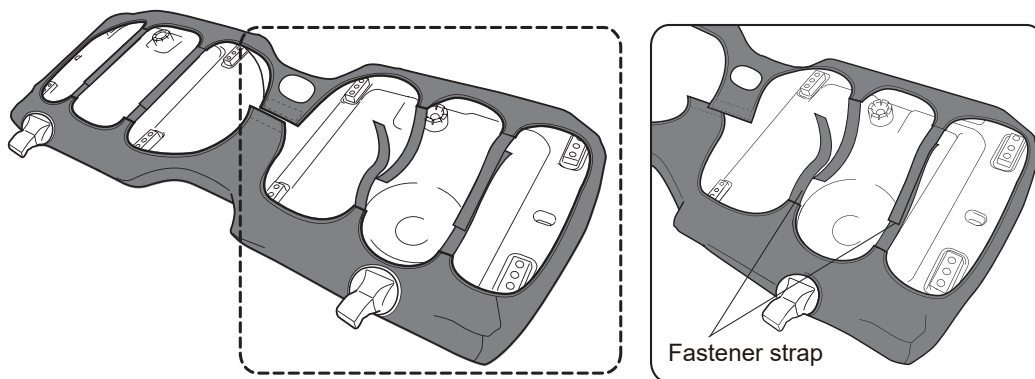

2. Flip the seat, connect four fastener straps and one center fastener. Make sure all seat hardware fasteners, latch handle, and latch are still accessible.

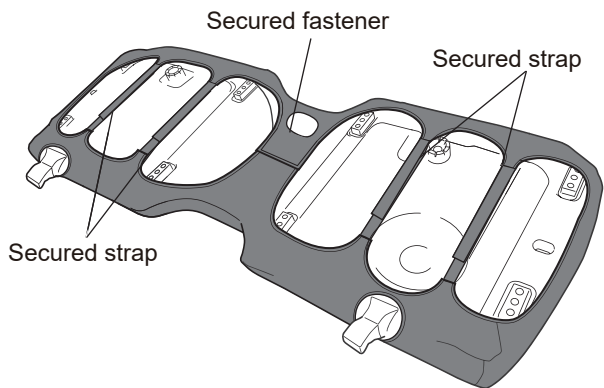

3. Secure all straps and reinstall the seat.

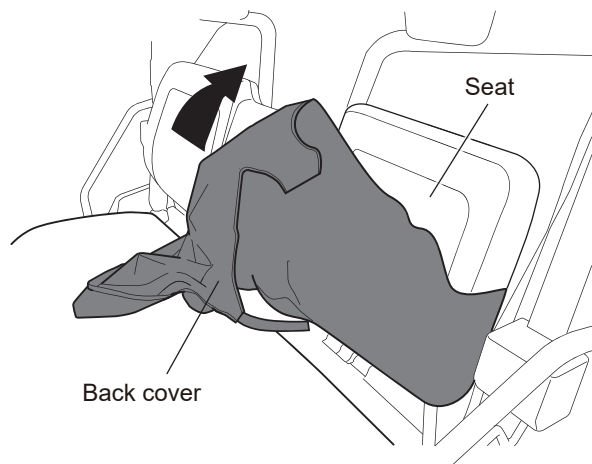

4. Fit the back cover from underneath, pulling up and over the seat back.

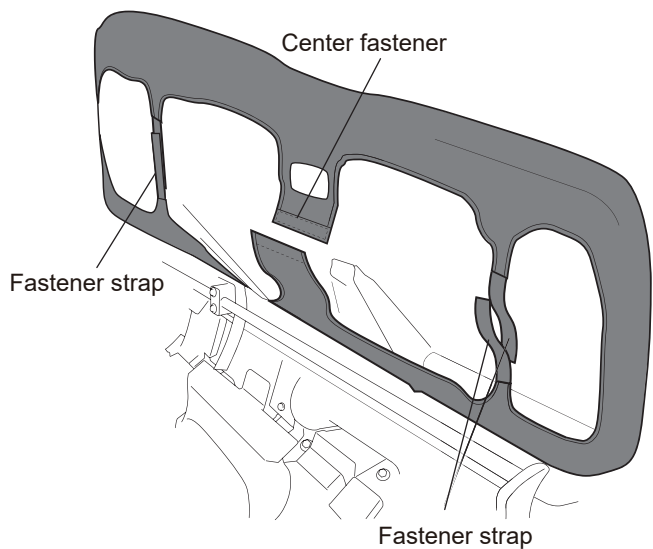

5. On seat back, connect two fastener straps and center fastener.

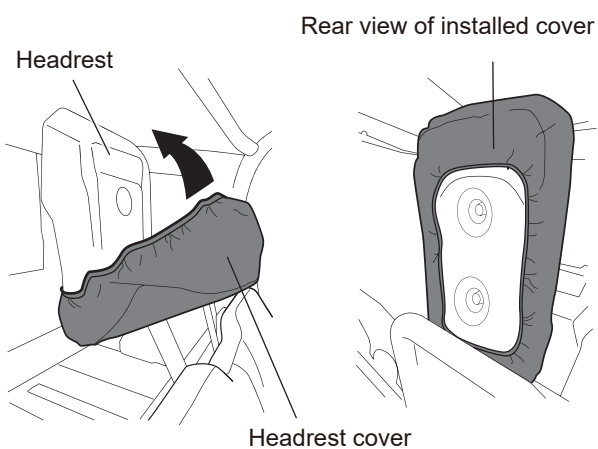

6. Place the headrest covers over the headrests and pull the elastic edges all the way around headrest.